

# **The Influence of Value Fit on Safety Performance: A Survey of Employees of Construction Enterprise in Tangshan City, Hebei Province, China**

**Li Xinyang**

Rajamangala University of Technology Rattanakosin, Thailand.  
E-mail: 2102784552@qq.com

**Received** May 1 2023; **Revised** May 25, 2023; **Accepted** June 29, 2023

## **Abstract**

The objectives of this research were to examine (1) the relationship between value fit and safety performance of employees in construction enterprises; (2) the relationship between value fit and self-efficacy of employees in construction enterprises; (3) the relationship between self-efficacy and the safety performance of employees in construction enterprises; and (4) the mediating relationship between value fit and safety performance of employees in construction enterprises.

Under the guidance of quantitative research methodology, this research adopts an online questionnaire to conduct an empirical survey. The study was able to have 403 employees from the construction enterprises in Tangshan City, Hebei Province, China, participated in the survey, which was made possible with the help of enterprise leaders, colleagues, and friends by simple random sampling. Data were analyzed using SPSS 24.0 and AMOS 24.0 software, which included descriptive statistical analysis, reliability and validity tests, confirmatory factor analysis, and structural equation model analysis.

Major Findings were (1) value fit has a significant positive correlation with safety performance; (2) value fit has a significant positive correlation with self-efficacy; (3) self-efficacy has a significant positive correlation with safety performance; and (4) self-efficacy partially mediates the relationship between value fit and safety performance. This research provides a feasible management framework to improve the safety performance of construction enterprises, promote the construction management of engineering projects, and provide practical management suggestions.

**Keywords:** Value Fit; Safety Performance; Self-efficacy; Construction Enterprises; Hebei.

## Introduction

This research takes the employees of construction enterprises as the research object, which aims to explore the influencing factors of safety performance and provides an effective management framework for improving the safety performance of construction enterprises. This section states the research background, significance, questions, objectives, limitations, and thesis outline. In 2022, China enters the stage of building a moderately prosperous society in all respects and has achieved the goal of poverty alleviation (Guo & Liu, 2022). With the continuous improvement of social infrastructure and the increasing demand of people for infrastructure construction and the improvement of the living environment, the construction industry gradually occupies a pivotal position in the national economy. It has developed into an unshakable pillar industry (Liu et al., 2018). According to the data released by the *National Bureau of Statistics of China in 2022*, the total annual output value of China's construction industry in 2021 was 24844.327 billion Yuan, with a growth rate of 10.01% (accounting for 24.71% of the GDP). The construction industry employs more than 54 million people, making it the world's most significant labor force.

However, the management mode and technology in the field of construction engineering continue to innovate, and the scale continues to expand; its increasing objective needs and the frequent safety problems of construction engineering are also widely concerned by society (Akinosho et al., 2020). According to the accident information disclosed by the *Ministry of Housing and Urban-Rural Development*, the number of production safety accidents and deaths in China's housing and municipal engineering from 2012 to 2021 is rising. In 2021, there were 773 safety accidents, and 904 people died. Compared with 2020, the number of accidents increased by 39, an increase of 5.31%, and the number of deaths increased by 64, an increase of 7.62%. The number of casualties caused by safety accidents in the construction industry ranks second in the national economy, second only to the mining industry (Tong et al., 2022). Construction engineering accidents are more frequent, which is determined by the inherent and unforeseeable risks faced by the construction industry (Trinh & Feng, 2020).

The progress of science and technology and the development of society have enriched the field of human activities, and the contents of the projects have become more diverse and complex. However, it cannot be ignored that the safety accidents that occurred in the operation of some projects have also led to more severe consequences than before (Ye et al., 2022). Safety management needs to emphasize safety accident prevention activities as far as possible to avoid the occurrence of safety accidents. To prevent safety accidents in advance, managers and employees must identify the causes of safety accidents and then take adequate preventive measures to improve safety performance (Sukamani et al., 2021).

In addition, according to the researchers, the fundamental cause of accidents in the construction industry is unsafe behavior caused by the management's neglect of safety control and the lack of safety awareness of personnel (Rahimi & Mohammadzade, 2015). The unsatisfactory safety performance of individual workers leads to the failure of the overall safety level to meet expectations (Kang et al., 2020). Safety performance is always an important index to measure the level of construction safety management and enterprise operation performance (Sukamani et al., 2020). At present, the research on the influencing factors of safety performance mainly focuses on the safety climate, safety culture, safety attitude or safety awareness, and the behavior of senior leaders (Chen et al., 2021; Newaz et al., 2019). Most of the research does not consider Chinese construction projects' social and cultural characteristics and only applies the foreign research hotspot directly to the local empirical research (Kang & Wu, 2020). However, although some research results have been achieved, there still needs to be a need to improve the safety production situation of the construction industry effectively.

Safety performance originates from work performance and is an independent category of work performance. It can be used to measure the actual completion of safety management work of employees and enterprises and reflect the results of safety operations (Trinh & Feng, 2020). According to the accident causation theory, the unsafe behavior of humans is the primary factor causing the accident. The unsafe state of the limiting objects and the unsafe behavior of individuals should be paid attention to in the management and control of safety accidents (Su et al, 2019). Therefore, achieving an ideal level of safety management is not accessible by relying only on enhanced technology to improve the safety state of products. Managers also need to start from the individual factors of employees and then fundamentally improve safety performance.

With the deepening of research, the relationship between individuals and organizations has attracted the attention of scholars. Value fit is the most frequent field of organizational behavior research at present (Hou, 2019). The individual and organizational values fit can generate a sense of belonging for employees psychologically, improve their job recognition, and thus improve their satisfaction and loyalty, which is an essential factor for the long-term development of employees in the enterprise (Mi et al., 2020). So, improving employee performance is a complex problem faced by every enterprise and a critical problem for enterprises (Amornkitpinyo et al., 2022). It has become a hot topic in the academic field to study how to explore the value fit to the enterprise better, apply the research results in this field, recruit more suitable talents for the enterprise, stimulate the work enthusiasm of the employees, enhance the confidence, and thus improve the performance of the employees (Lou, 2018).

The personal-environment fit theory holds that human behavior results from the interaction between the individual's inner personality and the environment (Yang & Deng, 2020). Value is the core and stable part of humans and organizations. The interaction between the individual's inner values and the organization's values will exert positive or negative effects on individual behavior (Pataki-Bittó, 2021). Safety performance is the cornerstone of construction enterprise performance, and positive individual behavior can produce positive work performance (Newaz et al., 2023). Therefore, the study of individual behavior from the perspective of value fit is the core content of this kind of problem, which can make clear the factors affecting individual performance from the most fundamental aspect and achieve the purpose of improving safety performance through the active intervention of individual and organization interaction.

The social cognitive theory proposes that self-efficacy refers to an individual's ability to judge and confidence in whether he or she can complete the target task. Such expected judgment not only reflects an individual's cognitive state but also affects how an individual behaves (Darvishmotevali & Ali, 2020). Self-efficacy is not directly related to an individual's ability but refers to their confidence in using their ability to complete a task. The higher the self-efficacy of employees, the more likely they are to have a strong belief in safety, strictly abide by the requirements of safety norms at work, and even take safety measures that are not mandatory to improve safety performance further (Sulistyo & Suhartini, 2019).

For construction enterprises, value fit as an individual value judgment standard and belief can guide employees' work stances and behavior norms and play an essential role in safety performance (Luo, 2020). At the same time, the safety performance of employees is affected by their self-efficacy. At different risk perception levels, the intensity of the impact of personal values driven by self-efficacy on safety performance is different (Chen & Li, 2019).

Based on this, under the guidance of personal-environment fit theory, social cognitive theory, and accident causation theory, this research builds a theoretical framework affecting safety performance, providing theoretical support for exploring the relationship between value fit, self-efficacy, and safety performance. In addition, this research takes the employees of

construction enterprises in the Tangshan City of Hebei Province, China, as the research object, aims to explore the factors that affect safety performance and provide an effective management framework to provide practical suggestions for promoting the safety performance of construction enterprises.

## **Research Significance**

### **Theoretical Significance**

Based on personal-environment fit theory, social cognition theory, and accident causation theory, this research explores the mechanism of value fit, self-efficacy, and safety performance of employees in construction enterprises. In the theoretical significance, it includes the following three points,

First, it enriches the theoretical research of safety performance. Currently, most safety performance studies focus on the individual or the organizational level. However, less attention is paid to the combination of individuals and organizations, such as the perspective of value fit. This research explores the impact of value fit on safety performance from the level of individuals and enterprises. It also provides a new research perspective and idea for the safety performance of construction enterprises.

Second, it enriches the theoretical research of value fit. Current studies on value fit focus on the influence of value fit on knowledge employees, such as enterprise employees and university teachers. However, only some studies have paid attention to the impact of value fit on safety performance in the construction enterprise context. So, this research adds the impact of value fit factors on the safety performance of construction enterprises.

Thirdly, it enriches the theoretical research on the mediating effect of self-efficacy on value fit and safety performance. As an essential factor in the research of individual behavior in organizational behavior, self-efficacy has been widely used in the study of the relationship between individuals and organizations and has obtained many research results. However, there are few works of literature based on empirical studies in construction enterprises. From the perspective of employees in construction enterprises, this research introduced the individual influencing factors of self-efficacy to explore the indirect effects of self-efficacy on value fit and safety performance. This research complements the influencing factors of employee self-efficacy in construction enterprises and enriches the theoretical research on the role of self-efficacy as an intermediary.

### **Practical Significance**

This research establishes a management framework to promote the safety performance of construction enterprises and provides an essential practical reference for the employees and managers of construction enterprises. The practical significance is mainly reflected in the following two aspects.

On the one hand, it is beneficial for employees of construction enterprises to establish correct work values and improve occupational commitment and work attitude. Under the influence of enterprises' values, employee values tend to match enterprise values. Furthermore, employees can improve their self-efficacy, have complete confidence in their work, pay more attention to the requirements of work tasks, carry out safety production in a standardized way, enhance their belief in completing work tasks, achieve personal career goals, and ultimately promote the safety performance of construction enterprises.

On the other hand, for the managers of construction enterprises, it is conducive to the construction of enterprises' values and the improvement of the safety performance management

ability of construction enterprises. This research establishes a practical framework for improving the safety performance of construction enterprises. Managers can realize the expected growth of employees and enterprises by strengthening the construction of corporate values so that employees' personal and corporate goals are consistent and improve the matching degree between employees' and corporate values. The more an employee's values match those of the enterprises, the more loyal individual will be to the enterprises and give full play to personal abilities. In addition, managers must pay attention to the changes in employees' mental states and take communication and other ways to enhance employees' confidence in completing safe production activities. To improve employees' self-efficacy at work, ultimately promote the safe performance of enterprises, achieve stable development, and finally achieve the goal of a double win between employees and enterprises.

## Research Objectives

Given the introductory background, this study considers four-fold objectives:

1. To examine the relationship between value fit and safety performance of employees in construction enterprises.
2. To examine the relationship between value fit and self-efficacy of employees in construction enterprises.
3. To examine the relationship between self-efficacy and the safety performance of employees in construction enterprises.
4. To examine the mediating relationship between value fit and safety performance of employees in construction enterprises.

## Literature Review

Based on the research objectives, we further confirm the research context, which is based on a construction enterprise in Tangshan, Hebei Province, China. Based on personal-environment fit theory, social cognitive theory, and accident causation theory, this research provides theoretical support for exploring the relationship between value fit, self-efficacy, and safety performance. Therefore, this research proposes the research hypothesis of the relationship between variables and constructs the theoretical framework affecting safety performance.

### Research Context

As a close neighbour of Beijing, Hebei Province has unique geographical advantages. Tangshan City, located in the eastern part of Hebei Province, is the central city of the Beijing-Tianjin-Hebei Industrial Base and the northeast sub-central city of the Beijing-Tianjin-Hebei City cluster. Tangshan City is the cradle of modern industry in China, with a solid industrial foundation, and undertakes several key national industrial construction projects. In 1984, The State Council approved Tangshan City as one of China's 13 "megacities." In 2021, Tangshan City will have a land area of 13,472 square kilometres and a population of 7,717,900. In 2014, the GDP of Tangshan City was 622.53 billion yuan, ranking first in Hebei Province and 19th in China. In recent years, the GDP of Tangshan City still leads other cities in Hebei Province. According to Tangshan City's 2021 Statistical Bulletin of National Economic and Social Development, the GDP of Tangshan City in 2021 was 823.06 billion yuan, ranking first in Hebei Province.

As an essential part of the national economic development, the construction industry is also a necessary support for the social and economic development of Tangshan City. In 2021, the added value of the construction industry in Tangshan City reached 41.69 billion yuan, an increase of 12.0% over the previous year. The building area of construction enterprises was

42.95 million square meters, up 16.5% yearly. The area of completed buildings reached 9.369 million square meters, an increase of 10% year-on-year. Construction enterprises with general contracting and specialized contracting qualifications achieved a profit of 1.2 billion yuan, up 5.9% yearly. In addition, according to the 2022 Statistical yearbook released by the Tangshan City Municipal Bureau of Statistics, there will be 383 construction enterprises in Tangshan City in 2021, with 75,567 employees.

Under the government's support, Tangshan City of Hebei Province, China, has meaningful opportunities for economic development, and the construction industry, as an essential pillar of the economic development of Tangshan City, plays an essential role in social development. According to the previous research background, the safety of construction enterprises is the key to restricting the development of construction enterprises. Therefore, based on the research context of construction enterprises in Tangshan City, Hebei Province, China, this research further explores the factors affecting safety performance and provides practical management suggestions for promoting the safety performance of construction enterprises.

### **Theoretical Basis**

#### **Personal-environment Fit Theory**

Frank Parsons first proposed the concept of personal environment fit. It is used in career decision-making and points out that an individual's career choice results from the interaction between their conditions and environment (Wu et al., 2020). Personal-environment fit is broadly defined as the compatibility of characteristics of both individuals and the environment in the interaction process (Yang & Deng, 2020). The theory holds that in the interaction between individuals and the environment, the degree of matching between individuals and the environment mainly affects the individual's work attitude, turnover behavior, and work performance (Yasmeen, 2021). Individuals with a high degree of environment matching have more outstanding working status and degree of commitment. On the contrary, individuals with a low degree of environment matching have lower work performance and are more likely to have turnover behavior (Ismail, 2021).

The research shows that the matching between people and the environment at different levels may produce different degrees of results, and the matching between different levels is interrelated and interactive (Yasmeen, 2021). However, the personal-organization fit is a vital aspect of human-environment matching, in which any individual depends on an organization. The individual employee is the most basic unit of the organization, and the organization is where the individual employee works, studies, and lives (Yang & Deng, 2020).

In recent years, with the in-depth study of personal-environment fit, this theory has been used to guide the process of organizational socialization of employees, attach importance to the humanistic care of organizations and the embedment of organizational culture, shorten the run-in time of the collision, and promote the process of integration between employees and organizations (Ke & Yang, 2021). Therefore, scholars have proposed the definition of personal-organization fit in enterprise studies. At the same time, most researchers believe that personal-organization fit is the highly fit and consistency between people and organizations in terms of norms and values (Wu et al., 2020). However, although Muchinsky & Monahan (1987) and Kristof (1996) put forward different dimensions of understanding personal-organization fit, they all agree that value fit is the core element of personal-organization fit (Yasmeen, 2021).

#### **Social Cognitive Theory**

The research on social cognition originated in the 1980s. Bandura (1986) elaborated on social cognition theory and pointed out that its core content clarified the interaction between

cognitive factors, environmental factors, and behaviors (Beauchamp et al., 2019). The theory shows that cognitive factors are composed of self-efficacy and outcome expectations. Self-efficacy reflects how an individual evaluates his or her ability level, and outcome expectation reflects an individual's understanding, judgment, and prediction of own behavior results (Schunk & DiBenedetto, 2020).

Bandura (1986) defined self-efficacy as an individual's measurement of their ability and independent assessment of whether they can achieve a specific goal, which is influenced by many factors, such as experience and social environment (Beauchamp et al., 2019). Self-efficacy has an existential determining effect on the change of individual motivation and behavior adoption. People only take on what they can handle and instead choose tasks they are confident they can accomplish (Schunk & DiBenedetto, 2020). Self-efficacy makes people affected by the surrounding environment and other factors to different degrees. Individuals with low self-efficacy lack confidence in their abilities and are easily affected by external factors. They think the tasks to be completed are challenging and difficult to implement positive coping actions. While individuals with high self-efficacy have confidence in their abilities, dare to deal with challenges, and give full play to their skills to complete tasks successfully (Wilde & Hsu, 2019).

Therefore, as an essential part of individual cognitive factors, self-efficacy can be preliminarily predicted to impact safety performance positively. Studies have pointed out that employees with high self-efficacy are more confident that their abilities are enough to deal with and solve problems at work. They are more invested in the work of construction enterprises. They do not flinch in the face of difficulties and keep trying and making efforts to improve safety performance (Li & Zhao, 2020).

### **Accident Cause Theory**

Heinrich (1931) first put forward the representative theory of safety management — accident causation theory. The theory of accident causes points out that the unsafe behavior of people and the unsafe state of objects cause most accidents. To be specific, unsafe human behavior refers to dangerous illegal work behavior, such as failure to implement the operation according to the rules and regulations and not properly wearing protective equipment. The unsafe state of the object refers to objective shortcomings in the working environment, such as the failure of the machine and the damage of protective equipment. In addition, part of the unsafe state of the object also comes from the unsafe behavior of people, such as the failure to comply with the requirements of the process before the operation of the safety test, resulting in machine failure; do not wear protective equipment according to the regulations, resulting in an emergency without adequate protection of equipment (Fu et al., 2020). The above situations quickly cause significant safety accidents, and the personal safety of workers and orderly production activities have a significant impact. Primary prevention is the core of safety management, and managers and employees must try their best to reduce similar safety risks and improper operations. Although it is also essential to remedy after the event, the severe consequences caused by the safety accident have been challenging to recover from (Yang, 2022).

In addition, the theory holds that the direct cause of the accident is the unsafe behavior of people and the unsafe state of objects, genetic or social environmental factors lead to individual defects, individual defects cause individual unsafe behavior or the unsafe state of objects, individual unsafe behavior or the unsafe state of objects cause accidents, accidents cause injury (Zhang, 2021); this theory specifically points out that the control of individual unsafe behavior or unsafe state of things is the core of safety management to control the safety accident rate and interrupt the chain of accidents to avoid the occurrence of accidents (Chen,

2022). Therefore, since the unsafe behavior of people and the unsafe state of objects are the leading causes of accidental consequences, it is not enough to rely on technology only to ensure the safe state of objects to prevent and control accidents fundamentally. It is necessary for managers to pay attention to employees' individual factors and behavior to conduct comprehensive management and achieve the goal of improving safety performance (Trinh & Feng, 2020).

### **Research Variables**

#### **Value Fit**

Value is an individual's view of something, and the subjective cognition generated after thinking activities, which can continuously affect the individual's goal, motivation, and behavior (Na & Su, 2019). Values reflect an individual's inner belief in all kinds of things. It can guide individual actions, influence evaluation criteria, and motivate individuals to improve themselves. It is the preference of individuals and society for specific behavior patterns and social conditions (Mao, 2016).

The concept of personal-organization fit originated from the personal-environment fit theory proposed by Lewin (1935). An individual's behavior in choosing his/her own behavior is the result of the joint action of both the individual and the environment, and whether an individual's behavior and attitude are positive is mainly explained through the interaction between the individual and the environment. A person's personality and personality are determined by the values used. At the same time, a person's values determine the understanding and measurement of the organization's external environment (Lou, 2018). In addition, Cable & Judge (1996) concluded that the evaluation and evaluation of the organizational values applied by job seekers in the process of job hunting are mainly achieved by comparing the degree of matching between their values and perceived organizational values rather than by the degree of similarity of statistical characteristics (Jin et al., 2018).

In the empirical research review, many scholars have made different interpretations of the definition of value fit. Value fit refers to the extent to which an individual's understanding of the enterprise's behavior style and success criteria is consistent with the inner hypothesis of the individual's behavior pattern (Ke & Yang, 2021). Value fit refers to the degree to which members accept and identify with organizational values (Mao, 2013). Value fit is the degree to which an individual's understanding of some of the most basic ways of being and doing things in an organization is consistent with individual assumptions (Hou, 2019). Value fit refers to the degree of similarity between employee personality traits and organizational values, which is a mutual matching and selection relationship (Lou, 2018). Based on this point, this research defines the value fit of employees in construction enterprises as, the employees accepting and recognizing the enterprise's values and tending to be consistent between personal and corporate values.

#### **Self-Efficacy**

Psychologist Bandura proposed the concept of self-efficacy in the 1980s. Bandura (1977) pointed out that even though individuals know the arrangements and actions they should take, they may not take these actions to the greatest extent in actual situations because their thinking judgment plays an intermediary role between knowledge and actual actions, that is, how individuals evaluate their abilities and their self-perception of efficacy will significantly affect motivation and subsequent behaviors (Eastman & Marzillier, 1984). Based on this, he defined self-efficacy as the perceived strength of an individual's ability when facing a specific task.



With the continuous application of research, many scholars have defined self-efficacy differently based on different research situations. Holden et al. (2017) pointed out that self-efficacy does not refer to the actual ability level of an individual but to the assessment of the degree of confidence that an individual can use his ability to complete a particular task (Holden et al., 2017). Schunk & DiBenedetto (2020) defined self-efficacy as an individual's cognition of the ability to solve problems successfully and achieve goals. This kind of cognition can guide individuals to strengthen their intrinsic motivation and take active actions to achieve the expected results when facing challenging tasks (Schunk & DiBenedetto, 2020). Javed et al. (2021) defined self-efficacy as an individual's confidence and belief in solving obstacles and adjusting fear to achieve set goals when facing challenging tasks (Javed et al., 2021). Doménech-Betoret et al. (2017) defined self-efficacy as individuals' beliefs about their ability to organize and execute actions to achieve specific achievements (Doménech-Betoret et al., 2017). Nguyen et al. (2017) defined self-efficacy as the degree of confidence that individuals have behavioural abilities in specific situations (Nguyen et al., 2017).

The above definitions are different opinions of different scholars on self-efficacy. In these definitions, scholars did not distinguish according to specific industry fields but put forward the concept from the whole. However, the idea of all definitions is the same; self-efficacy is a subjective judgment of an individual's belief in his ability. Based on this point, the self-efficacy of employees in construction enterprises is defined in this research as, the belief that employees perceive themselves to complete the safety production task of the enterprise.

### **Safety Performance**

In *the Code for Occupational Health and Safety Management System*, safety performance is defined as the measurable results of an organization's safety and health management system that are related to the organization's internal occupational safety risk control and management according to the goals, policies, and purposes of occupational safety and health (Silva & Amaral, 2019). In the specific practice, safety performance is a series of production behavior results per the company's safety strategy, objectives, and risk control (Kang & Wu, 2020). Safety performance can be reflected in the realization of the safety production objectives of enterprises. It can also be shown as the result of the enterprise's control of safety production risks (Maliha et al., 2021).

Trinh & Feng (2020) believes that an enterprise's safety performance is the overall performance of its safety system in production and operation (Trinh & Feng, 2020). Tremblay & Badri (2018) pointed out that an enterprise achieves safety performance through safety management, which reflects the enterprise's ability to control existing safety risks (Tremblay & Badri, 2018). Jazayeri & Dadi (2017) stated in his research that safety performance refers to the process of subdividing the objectives and guidelines within the work responsibilities of organizational members, establishing the result evaluation criteria, and making a fair assessment of the safety work promoted by enterprises, analyzing the results of safety management, and implementing improvements (Jazayeri & Dadi, 2017).

However, based on the current review of research on safety performance, Neal & Griffin's (2002) definition of safety performance is generally accepted and adopted. They believe that safety performance includes safety compliance behavior and safety participation behavior (Neal & Griffin, 2002). Safety compliance behavior is the explicit requirement for employees to ensure safe production and operation. It is the core behavior that employees must follow, such as strict compliance with the safety rules and regulations of the enterprise, the use of necessary safety facilities, and safe operation in line with the norms (Pourmazaherian & Musonda, 2022). The safety participation behavior does not belong to the rigid requirements of the enterprise for employees. However, it emphasizes that employees voluntarily contribute

to the safety activities of the enterprise and take the initiative to ensure production safety, such as correcting the dangerous wrong operations of colleagues and proposing specific measures to strengthen safety control (Lyu et al., 2018). Based on this point, this research defines safety performance as, employees' safety compliance and participation behaviors in production activities.

## Research Hypotheses

### **The Relationship between Value Fit and Safety Performance**

As people's inner psychological characteristics, values have complex meanings and structures, including people's cognition and value evaluation of all aspects of work and life (Na & Su, 2019). Many scholars have proved that work values have a significant predictive effect on job performance. For example, Jalalkamali et al. (2016) show that work values are the criteria for evaluating and judging work demands and results and can guide employees' attitudes and performance levels (Jalalkamali et al., 2016).

However, few studies have focused on the impact of value fit on safety performance. Na & Su (2019) took the new generation of employees in coal mining enterprises as the research object, and the results showed that work values could significantly affect the safety performance of employees (Na & Su, 2019). Zhang (2021) analyzed the construction methods of enterprise safety culture and pointed out that only by strengthening the construction of enterprise safety culture system. Improving employees' working ability, making them keep up with their ideological consciousness, comply with the safety production management system, and effectively perform their duties on the job (Zhang, 2021).

When employees enter an enterprise that matches their professional values, the vision and mission established by the enterprise, the prestige, the assigned task, the prescribed compensation and benefits, and the working atmosphere the organization provide meet their expectations for the enterprise (Hou, 2019). And the employees will have a strong sense of identity and belonging to the organization, show more enthusiasm for work, and achieve better work performance (Lou, 2018). Therefore, the value fit can better promote safety performance in construction enterprises. Based on those discussions, this research believes that value fit can positively affect the safety performance of construction enterprises and proposes a hypothesis.

*H1. Value fit has positively correlated with safety performance.*

### **The Relationship between Value Fit and Self-efficacy**

Putri et al. (2018) research showed that an individual's work values could guide the formation and change of their emotional intelligence and emotional state. Emotional state and self-efficacy can make an individual's self-efficacy fluctuate in strength (Putri et al., 2018). Barni et al. (2019) pointed out that value is essential in predicting employees' self-efficacy. A high match between individual values and the work environment can motivate employees to have a high level of self-efficacy (Barni et al., 2019). Wongsuwan & Na-Nan (2022) explored the mediating role of self-efficacy and job satisfaction in the relationship between personal-organization fit and employees' job adaptation and confirmed that the dimension of value fit could effectively promote employees' self-efficacy (Wongsuwan & Na-Nan, 2022).

On the premise of matching the values of individuals and enterprises, employees will form and show positive attitudes that are more conducive to the career development of organizations and individuals, such as more job satisfaction and stronger self-efficacy, which can reduce the pressure of job burnout of employees to a certain extent (Mao, 2013). Self-efficacy influences the activities that individuals choose to engage in and the working environment they choose. In looking for jobs, people can evaluate themselves and select jobs

more suitable for their abilities and personalities. In such a working environment, they can fully play their talents (Li & Zhao, 2020). Therefore, when employees perceive that their values fit in construction enterprises, they can better promote personal self-efficacy and motivate themselves to complete work tasks confidently. Based on those discussions, this research believes value fit can positively affect employees' self-efficacy in construction enterprises and proposes a hypothesis.

*H2. Value fit has positively correlated with self-efficacy.*

### **The Relationship between Self-efficacy and Safety Performance**

Based on the social cognitive theory, self-efficacy reflects an individual's measurement of their ability and independent assessment of whether they can achieve a specific goal. It can affect an individual's effort, decision-making, and performance (Nguyen et al., 2017). Many scholars have proved through research that a high level of individual self-efficacy can promote job performance. For example, Li & Qi (2017) pointed out that self-efficacy connects employees' cognition and behavior. After employees adopt voice behavior, superiors' attitude toward and adoption of voice behavior will significantly impact employees' self-efficacy, ultimately manifested as a change in work performance (Li & Qi, 2017). Shi et al. (2019) proved through empirical research that self-efficacy guide employees to implement different work behaviors and motivate them to achieve higher levels of work performance. Individuals with higher self-efficacy would be more willing to engage in challenging tasks and make more efforts to achieve better performance results, further strengthening employees' self-efficacy (Shi et al., 2019).

Safety performance is an independent category of job performance. Some scholars have also paid attention to the impact of self-efficacy on safety performance. Sun et al. (2018) took pilots as research objects and found that self-efficacy can guide pilots to adopt more active safety compliance behaviors and safety participation behaviors (Sun et al., 2018). Li & Zhao (2020) pointed out that miners with high self-efficacy had stronger willpower and belief in the process of task implementation, which had a noticeable incentive effect on their competence and safety performance (Li & Zhao, 2020).

In studies on safety performance, researchers point out that high self-efficacy can enhance individuals' willpower to face challenging tasks, effectively curb irresponsible behaviors, and improve work safety performance (Li & Zhao, 2020). Therefore, in construction enterprises, employees have high self-efficacy, which can effectively promote safety performance. Based on those discussions, this research believes that employees' self-efficacy in construction enterprises can positively affect safety performance and proposes a hypothesis.

*H3. Self-efficacy has positively correlated with safety performance.*

### **The Relationship between Value Fit, Self-efficacy, and Safety Performance**

Some scholars have studied the direct effect of values on safety performance but have yet to discuss its internal mechanism. Personality characteristics and values are essential factors affecting individual self-efficacy (Mao, 2013). Especially when the values of individuals and organizations are consistent, employees can still generate a high level of self-efficacy and confidence in the face of challenging tasks and are willing to constrain their behaviors according to the organization's requirements. Individuals with high self-efficacy have confidence in their abilities, dare to deal with challenges, and fully display their skills to complete the task successfully (Javed et al., 2021).

Ma & Liu (2021) conducted a questionnaire survey on 604 miners. The research results showed that when employees' values align with the organization's culture and development goals, they would have strong confidence in their safety capabilities and safe work. Self-

efficacy would prompt employees to pursue the realization of safety goals even in the face of challenging tasks. Employees with high self-efficacy will also try to take various measures to ensure safety (Ma & Liu, 2021). Mao (2016) took IT industry employees as the research object and explored the mediating role of self-efficacy between value fit and job performance. Studies have shown that value fit can promote employees' self-efficacy and then improve employees' work performance. Therefore, the research confirmed the mediating relationship between self-efficacy between values fit and job performance (Mao, 2016).

Combine with the above hypothesis, this research believes self-efficacy plays an intermediary role in the relationship between value fit and safety performance. In other words, in construction enterprises, the value fit can motivate employees to have a higher self-efficacy and can guide employees to take safety production measures to improve safety performance actively. When employees have strong enterprise values, they will pay attention to protecting the enterprise's interests and intend to undertake more responsibilities and tasks. Moreover, it can motivate employees to have a strong sense of self-efficacy, have a firm belief in safety production, and put their efforts into it to achieve a high level of safety performance. Based on those discussions, this research believes that the self-efficacy of employees in construction enterprises has an intermediary relationship between value fit and safety performance and proposes a hypothesis.

*H4. Self-efficacy has a mediating effect between value fit and safety performance.*

## Theoretical Framework

Based on the above literature review, this research identifies variables of value fit, self-efficacy, and safety performance based on personal-environment fit theory, social cognitive theory, and accident causation theory. Furthermore, the relationship between variables is discussed, and the corresponding research hypothesis is proposed. Based on this, the theoretical research framework for influencing safety performance is constructed, as shown in Fig. 1.

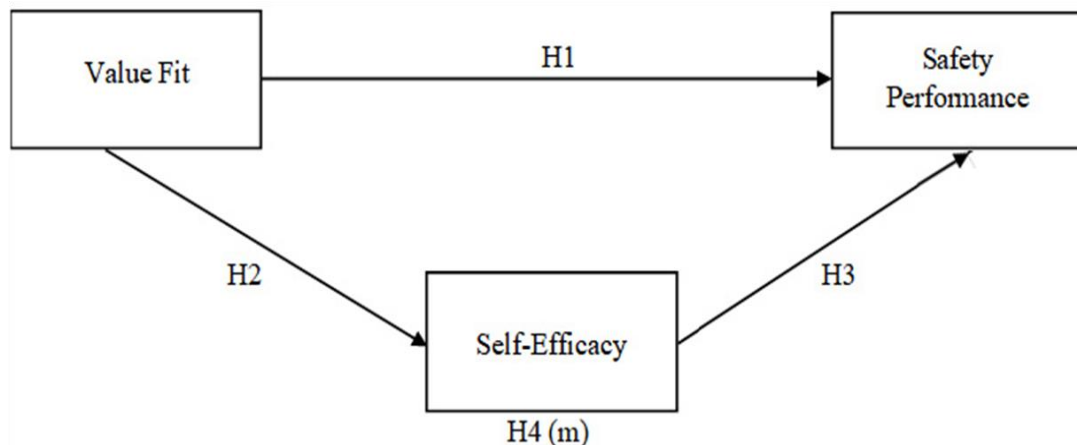

**Fig. 1.** The Theoretical Framework of this Research

## Research Methodology

This research adopts a quantitative research methodology to carry out an empirical investigation. This survey takes employees of construction enterprises in Tangshan City, Hebei Province, China, as the research objects and conducts an online questionnaire survey through the social network. This chapter includes population, sampling, measurement, questionnaires, data collection and analysis, and ethical considerations.

### **Population**

Based on the research objectives, this research takes construction enterprises in Tangshan City, Hebei Province, China, as the research context and employees of construction enterprises as the research objects. The target population of this research is the on-the-job employees of construction enterprises in Tangshan City. According to the 2022 Statistical Yearbook released by the Tangshan City Municipal Bureau of Statistics, there will be 383 construction enterprises in Tangshan City in 2021, with 75,567 employees. This research is based on a simple sample size calculation formula,  $n = N/[1+N(e)^2]$ , which calculates that the sample size should be no less than 398. To ensure that valid samples meet the requirement of sample size, more questionnaires will be distributed appropriately in the online questionnaire survey.

### **Sampling**

Based on the confirmation of the research population, to ensure that the research has a particular representation in the specific research area, employees of construction enterprises in Tangshan City, this research adopts the simple random sampling method in the target population to investigate the eligible research objects.

### **Measurement**

This research includes independent variable value fit, dependent variable safety performance, and mediating variable self-efficacy. The measurement of research variables is based on the mature scale proposed by scholars, which has been verified and is widely used. Among them, value fit adopts the personal-organization fit scale developed by Cable & DeRue (2002), including three dimensions (value fit, need-supply fit, and demand-ability fit), with three items in each dimension. This research focuses on value fit, so it draws lessons from the value fit dimension scale, which consists of 3 items (Cable & DeRue, 2002). The safety performance scale developed by Neal & Griffin (2002) based on safety atmosphere and safety behavior was used to explain safety performance, including two parts, safety compliance and safety participation, with a total of 12 questions (Neal & Griffin, 2002).

### **Questionnaire**

According to the contents of the items in the scale, this research formed a preliminary questionnaire. The subject content of the questionnaire consists of two parts: basic personal information of the respondents and questions on research variables, with 30 questions. Among them, 1 to 5 questions are entitled to demographic information (gender, age, marital status, work experience, Salary level; 6 to 8 questions entitled to value fit; 9 to 18 questions are entitled to self-efficacy; and questions 19 to 30 questions are entitled to safety performance questions. The variable item part's questionnaire content was studied using a 7-point Likert scale. The higher the score, the higher the satisfaction of respondents' perception of the corresponding item index. Since the questionnaire designed by the maturity scale was adopted in this research, it should have high reliability and validity and can be directly applied to the investigation. In order to ensure the smooth progress of the research, the contents of the initial questionnaire were translated by teachers of English majors and then verified and confirmed by management experts and professors. Finally, an effective questionnaire was formed. Please refer to the attachment for the contents of the questionnaire in both Chinese and English.

### **Data Collection**

With the help of friends, colleagues, and other social networks, 403 employees of construction enterprises in Tangshan City, Hebei Province, China, were randomly selected for

an online questionnaire survey. Questionnaires were released on WeChat, QQ, E-mail, and other networks, and questionnaires were collected with the help of Questionnaire Star software.

### **Data Analysis**

After the questionnaires were collected, the questionnaires with obvious patterns were removed from the questionnaire star system. Data analysis software SPSS 24.0 and Amos 24.0 were used for statistical analysis of the sample data. The analysis programs included descriptive statistics, reliability and validity tests, confirmatory factor analysis, and structural equation model analysis to test the applicability of the data. The proposed research hypothesis is verified and analyzed.

### **Ethical Consideration**

This research was carried out using by online questionnaire, which has reasonable objectivity and confidentiality. In order to avoid possible bias in participants' responses to questions during the survey, mature scales are used for reference in the questionnaire design, and professional translation and language conversion are used to ensure that the questionnaire items are easy to understand. In addition, although the questionnaire information is collected anonymously, it is only used for this research and has no other commercial nature. The data will be appropriately stored after the completion of this academic research.

### **Research Results**

The research was surveyed from December 2022 to January 2023. The survey was conducted by online questionnaire in construction enterprises in Tangshan City, and the respondents were employees. When the questionnaire is recalled for the first review, if all the answers are consistent and the IP. of the answer shows that it does not belong to Tangshan City, it will be regarded as an invalid questionnaire. A total of 448 questionnaires were distributed in this survey, and 403 valid questionnaires were collected, with an effective rate of 90.0%.

In order to facilitate the processing of research data in SPSS 24.0 and AMOS 24.0, the research variables were simplified into English acronyms, value fit (VF), self-efficacy (SE), and safety performance (SP). VF1 to VF3 was used to represent the value fit items; SE1 to SE10 was used to represent the self-efficacy items; and SP1 to SP12 was used to represent the safety performance items. In SPSS 24.0 software, descriptive statistical analysis and reliability and validity tests were carried out to test the effectiveness of the samples. In AMOS 24.0, confirmatory factor analysis and structural equation modelling are developed to validate research hypotheses.

### **Descriptive Statistical Analysis**

Descriptive statistical analysis is statistics of demographic information. In this research, the five personal basic information of the construction employee samples, including gender, age, marital status, working experience, and salary level, were statistically investigated, corresponding to the first to fifth items of the questionnaire. SPSS24.0 software is used to conduct descriptive statistics on samples, as shown in Table 1.

**Table 1.** The Descriptive Statistical Analysis

	Category	Frequency	Percentage
Gender	Male	373	92.6%
	Female	30	7.4%
Age	<30 years old	122	30.3%
	30-45 years old	263	65.3%
	> 45 years old	18	4.5%
Marital Status	Single	85	21.1%
	Married	309	76.7%
	Divorced	9	2.2%
Work Experience	< 5 years	17	4.2%
	5-10 years	374	92.8%
	> 10 years	12	3.0%
Salary Level	<5000 yuan	9	2.2%
	5000-10000 yuan	375	93.1%
	>10000 yuan	19	4.7%

Sample size: 403.

As can be seen from Table 1, among the 403 construction employees, 373 are male, accounting for 92.6%; there are 30 females, accounting for 7.4%. According to the age distribution, 385 employees are less than 30 and 30 to 45 years old, accounting for 95.6% and almost all of the sample population. However, there are only 18 employees over 45 years old, accounting for 4.5%. In terms of marital status, 309 employees were married, which is consistent with the sample above being dominated by young and middle-aged people. Regarding working experience, there were 374 employees with 5 to 10 years of working experience, accounting for 92.8%. In addition, from the perspective of the salary level, 375 employees have a salary between 5000 and 10000, accounting for 93.1%.

### Reliability Test

The reliability test is the stability of the test results under different conditions. In this research, Cronbach's  $\alpha$  coefficient was used to test the internal consistency of each scale. The higher the Cronbach's  $\alpha$  coefficient was, the better the reliability was. According to scholar suggestion, Cronbach's  $\alpha$  coefficient values of 0.60 to 0.65 is rejected; 0.65 to 0.70 is acceptable; 0.70 to 0.80 is quite reasonable; 0.80 to 0.90 is very good. In this research, test reliability results in SPSS 24.0 software are shown in Table 2.

**Table 2.** The Reliability Test

	Cronbach's Alpha	N of Items
	0.829	30
VF	0.804	3
SE	0.871	10
SP	0.889	12

As seen from Table 2, Cronbach's  $\alpha$  coefficient value of the total items is 0.829, and Cronbach's  $\alpha$  coefficient value of each variable tested separately is above 0.8, indicating that this scale has good reliability and is suitable for further verification and analysis.

### Confirmatory Factor Analysis

#### Validity Test

Before factor analysis, a validity test should be done first, which is mainly used to determine whether the measuring tool can accurately measure the things to be measured. Using SPSS24.0 software processing validity analysis can be judged by the KMO and Bartlett's spherical test results. The closer the KMO value is to 1, the more suitable it is for factor analysis. The KMO value is above 0.9, it is very suitable; between 0.8 and 0.9 is very good; between 0.7 and 0.8 is suitable; between 0.6 and 0.7 is barely suitable; between 0.5 and 0.6 is not suitable; anything below 0.5 is considered very inappropriate. Bartlett's sphericity test is suitable for factor analysis only when the chi-square value is significant, and the significance level is less than the given significance level. The results of the KMO test and Bartlett's spherical test in this research are shown in Table 3 below.

**Table 3.** The KMO and Bartlett's Test

KMO		0.884
Bartlett's Spherical Test	Approx. Chi-Square	4765.623
	df.	435
	Sig.	0.000

The KMO and Bartlett sphericity test results are shown in Table 3. The KMO value is 0.884, which is between 0.8 and 0.9, and the Bartlett sphericity tests significance value is 0.000, indicating that the questionnaire has good validity and is suitable for factor analysis.

#### Convergence Validity Test

According to the researchers, the combination reliability of all potential variables of the scale reached the minimum standard value of 0.6, and all were significant at the level of 0.001, indicating that the combination reliability of the model was good. AVE values of average variance sampling are all greater than 0.5, indicating that the model has good aggregation validity. The confirmatory factor analysis in this research was aggregated for the validity test, as shown in Table 4.

**Table 4.** The Convergence Validity Test

Potential Variables	C.R.	AVE
VF	0.848	0.651
SE	0.910	0.504
SP	0.933	0.540

It can be seen from Table 4 that in the convergent validity test, C.R. values of the combination reliability of each potential variable are 0.848, 0.910, and 0.933, respectively, which all exceed the expected reference value of 0.7. AVE values extracted by mean-variance were 0.651, 0.504, and 0.540, all greater than the average reference value of 0.5, and the convergence validity was reliable.

#### Discriminative Validity Test

To test the differentiation between different latent variables, the discriminative validity test was carried out on all research variables. The researcher pointed out that the absolute value



of the correlation coefficient between any two latent variables was less than the square root of the corresponding factor AVE, indicating a certain degree of differentiation between the three latent variables. The discriminative validity test of confirmatory factor analysis in this research is shown in Table 5.

**Table 5.** The Discriminative Validity Test

Potential Variables	VF	SE	SP
VF	<b>0.807</b>		
SE	0.489	<b>0.710</b>	
SP	0.465	0.591	<b>0.735</b>

Note: The diagonal is the square root of the corresponding dimension AVE.

As can be seen from Table 5, the absolute values of correlation coefficients between any two latent variables, VF, SE, and SP, are all less than the square root of the corresponding factor AVE. For example, the absolute value of the relative coefficient between latent variable VF and SE is 0.489, which is smaller than the AVE square root of latent variable VF 0.807 and the AVE square root of latent variable SE 0.710. Therefore, it shows a certain degree of differentiation among the three latent variables studied.

With the help of AMOS 24.0 software, the confirmatory factor analysis measurement model diagram was constructed, as shown in Fig. 2.

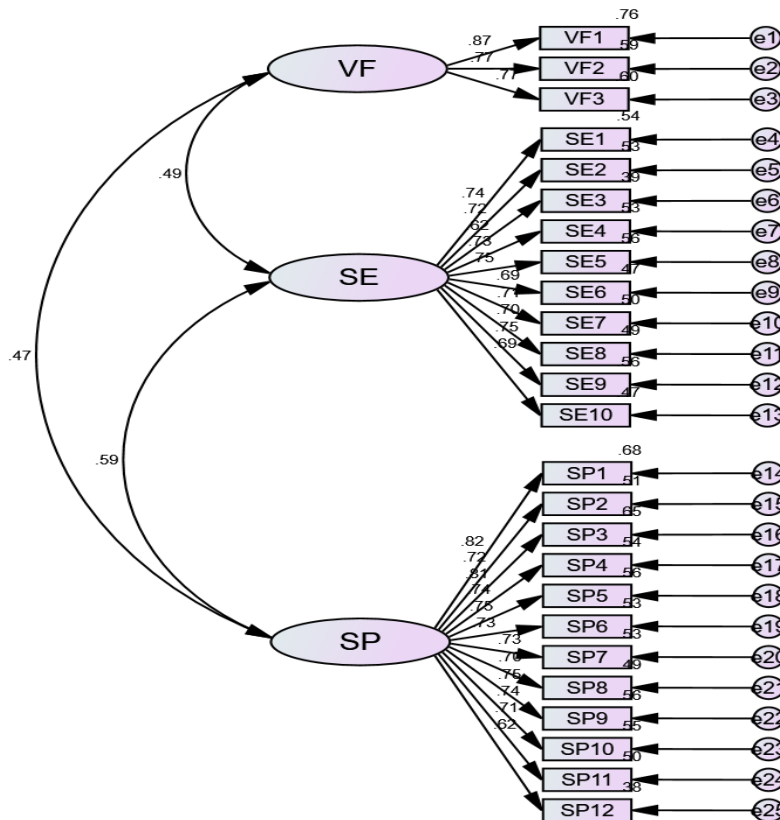

**Fig. 2.** The Confirmatory Factor Model Diagram

As shown in Fig. 2, the standardized structure diagram of the confirmatory factor analysis model shows that the factor load coefficient between each potential variable and its

measurement index is above 0.6, and all factor loads are within the range of the reference standard, indicating that the model has a good fit.

### Structural Equation Model

AMOS 24.0 software was used to build a structural equation model of the relationship between value fit, self-efficacy, and safety performance to verify the research hypothesis, the structural equation model diagram in this research is shown in Fig. 3.

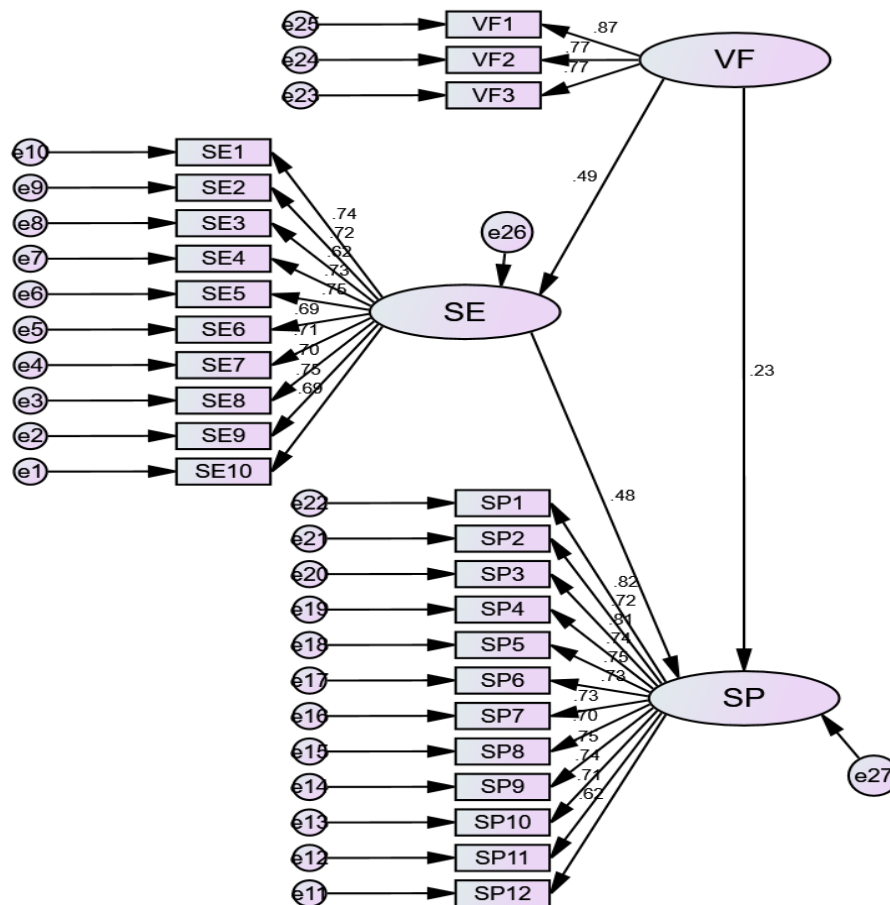

Fig. 3. The Structural Equation Model Diagram

### Model Fitting Test

In the measurement model, the structural fitting degree of the scale is judged by the fitting index. The indexes in the fitting index include: DCMIN/DF represents the chi-square divided by the degree of freedom, which measures the degree of interpretation of the data to the model. The value ranges from 0 to 5, representing the degree of data interpretation to the model. The general reference standard is less than 3. RMSEA refers to the goodness of fit index, which measures the model's interpretation degree to the sample data. The value ranges from 0 to 1, and the general reference standard is less than 0.08. The reference standard values of other indicators, GFI, AGFI, CFI, NFI, and RFI, should be over 0.9; the closer it is to 1, the higher the degree of model interpretation. Table 6 shows the test results of the fit index of the structural equation model.

**Table 6.** The Fitting Indexes of the Structural Equation Model

Fitting index	CMIN/DF	RMSEA	GFI	AGFI	NFI	TLI	CFI
Reference standard	< 3	< 0.08	> 0.9	> 0.9	> 0.9	> 0.9	> 0.9
Result	2.080	0.052	0.947	0.912	0.904	0.942	0.947

As seen from Table 6, the values of all test indexes are within the range of reference values, indicating that the model has reached a good fit, which is suitable for further analysis.

**Direct Effect Path Test**

The estimated value  $\beta$  of the detection path, the standardized path coefficient estimate, the standard error S.E., C.R., and the significance p-value were obtained by calculating the data in the structural equation model. The researchers pointed out that C.R. is more significant than 1.96 and the p-value is less than 0.05; it can be considered that this path coefficient can pass the significance test within the 95% confidence interval, indicating that the corresponding path hypothesis of the present model is valid. Otherwise, the hypothesis is not valid. The direct effect path test results are shown in Table 7.

**Table 7.** The Direct Effect Path Test

Hypothesis	Path	$\beta$	Estimate	S.E.	C.R.	P	Result
H1	VF→SP	0.232	0.151	0.037	4.117	***	Validated
H2	VF→SE	0.489	0.401	0.050	8.024	***	Validated
H3	SE→SP	0.477	0.381	0.053	7.222	***	Validated

\*\*\* indicate  $P < 0.001$ .

As can be seen from Table 7, the test results show that the C.R. of all paths is more significant than 1.96. The positive effect of VF on SP was significant ( $\beta=0.232, p<0.001$ ). The positive effect of VF on SE was significant ( $\beta=0.489, p<0.001$ ). The positive effect of SE on SP was significant ( $\beta=0.477, p<0.001$ ). Therefore, all direct effect path tests are feasible, and research hypotheses H1, H2, and H3 are valid.

**Indirect Effect Path Test**

With the above direct effect path tests supported, indirect effect path tests of structural equation models were further conducted to verify the mediation hypothesis H4 in the research. Indirect effect path detection results are shown in Table 8.

**Table 8.** The Indirect Effect Path Test

Effect	Path	Effect Value	Standard Error	Bootstrapping	
				95% CI	
Total effect	VF→SP	0.465	0.060	0.348	0.575
Direct effect	VF→SP	0.232	0.061	0.116	0.350
Indirect effect	VF→SE→SP	0.233	0.046	0.152	0.335

According to the detection results in Table 8, the upper and lower 95% interval of path VF→SP is [0.348,0.575], excluding 0, indicating that the total effect between VF and SP is significant, and the effect value is 0.465. The upper and lower 95% interval of the direct effect path is [0.116,0.350], excluding 0, indicating that the direct effect between VF and SP is significant, and the effect value is 0.232. The upper and lower 95% interval of the indirect path

VF→SE→SP is [0.152,0.335], excluding 0, indicating that SE significantly partially mediates between VF and SP, and the effect value is 0.233. Therefore, it can be confirmed that research hypothesis H4 is partially valid.

### Verification of Research Hypothesis

Based on the above research results, we further summarized the verification results of the research hypothesis, as shown in Table 9.

**Table 9.** The Verification Results of the Research Hypothesis

Research Hypothesis	Conclusion
H1 Value fit has positively correlated with safety performance.	Supported
H2 Value fit has positively correlated with self-efficacy.	Supported
H3 Self-efficacy has positively correlated with safety performance.	Supported
H4 Self-efficacy has a mediating effect between value fit and safety performance.	Partially Supported

As seen from Table 9, in the test of the direct effect relationship between value fit, self-efficacy, and safety performance of the research variables, there is a positive correlation between the two variables, and the research hypotheses H1, H2, and H3 are all valid. In addition, the test of the mediating role of self-efficacy between value fit and safety performance shows only partial significance. Therefore, the research hypothesis H4 is partially valid, expressing that self-efficacy partially mediates between value fit and safety performance.

## Discussions

The research results provide essential ideas for further discussion and analysis of the research on safety performance in construction enterprises. This section discusses the research results, draws conclusions, and puts forward practical suggestions and future research directions based on the research findings. Based on the above research results, we further discuss as follows:

Firstly, in the descriptive statistical analysis, we found that in 403 sample information of employees in construction enterprises, males accounted for 92.6%, and young and middle-aged employees (less than 45 years old) accounted for 95.6%. It is due to the particularity of the nature of work in construction enterprises, which takes physical strength as the primary form of work. Young and middle-aged males are more competent for the job requirements of this industry. However, females and the elderly are less engaged in this industry because of the differences in physiological factors. 76.7% of the employees are married, which is consistent with most young and middle-aged people in the sample. 92.8% of employees have five to 10 years of work experience, and 93.1% have salaries from 5,000 to 10,000 yuan. It is because the income of most employees is at the middle level of the average social wage, and the income of most employees is balanced within a specific range, which can meet the basic requirements of the income standard of employees in social life, and also makes the employees of construction enterprises have specific stability. Therefore, the overall sample information conforms to the actual situation, and the sample information is valid.

Secondly, in the reliability and validity test, Cronbach's  $\alpha$  coefficient value was 0.829, and Cronbach's  $\alpha$  coefficient value of each variable in the separate test and the total item was above 0.8, indicating that the research scale had good reliability. KMO value was 0.884, and the Bartlett sphericity tests significance value was 0.000, indicating that the questionnaire had good validity. Therefore, it is suitable for confirmatory factor analysis.

Thirdly, in the confirmatory factor analysis, convergence validity is first tested. The CR value of the combination reliability of each potential variable exceeds the average reference value of 0.7, and the AVE value of the mean-variance extraction exceeds the average reference value of 0.5, indicating that the convergence validity is reliable. Then, the discriminative validity is tested. The absolute value of correlation coefficients between any two latent variables is less than the square root of the corresponding factor AVE, indicating a certain degree of differentiation among the three latent variables studied. Most importantly, it can be seen from the standardized structure diagram of the confirmatory factor analysis model that the factor load coefficient between each potential variable and its measurement index is above 0.6, indicating that the confirmatory factor analysis model has a good fit.

Finally, in the structural equation model, the model fit is tested first. All the test indexes are within the range of reference standards, indicating that the model has an excellent fit degree. Then, the direct effect path detection showed that the C.R. of all paths was more significant than 1.96, and the p-value was less than 0.05, indicating that all direct effect path coefficients could pass the significance test within the 95% confidence interval. Therefore, hypotheses H1, H2, and H3 were valid. Based on this, the indirect effect path detection results show that the upper and lower 95% interval of the indirect path  $VF \rightarrow SE \rightarrow SP$  is [0.152, 0.335], excluding 0, and the effective value is 0.233, indicating that SE plays a partially mediating role between VF and SP. Therefore, it can be confirmed that research hypothesis H4 is partially valid.

To sum up, this research can effectively verify established research hypotheses through data analysis, and all the hypotheses proposed in this research are supported.

## Conclusion

This research takes the employees of construction enterprises in Tangshan, Hebei Province, China, as the research object. Based on the literature review, this research analyses the relationship between value fit, self-efficacy, and safety performance. Through data analysis and discussion, the following conclusions are drawn:

- (1) Value fit has a significant positive correlation with safety performance.
- (2) Value fit has a significant positive correlation with self-efficacy.
- (3) Self-efficacy has a significant positive correlation with safety performance.
- (4) Self-efficacy partially mediates the relationship between value fit and safety performance.

The empirical results confirm the research hypothesis, answer the research questions, and achieve the research objectives. According to the research results, effective practical recommendations are provided for enhancing the safety performance of construction enterprises.

## Practical Recommendations

Based on the findings of this research, we have the following three practical recommendations:

Firstly, managers of construction enterprises should attach importance to the guidance of corporate values and make employees' values consistent with corporate values. Publicizing corporate culture, brand, concept, goal, and other aspects creates good corporate values. Moreover, employees can identify well with the enterprise's values, keep their values, and highly match the enterprise.

Secondly, construction enterprise managers should pay attention to the psychological development of employees so that employees can improve their self-efficacy. Encourage positive psychological development and the professional quality of employees through appropriate policies, systems, and incentives. Moreover, strengthen production safety training

and education so that employees in the production operation can be more confident to complete the established task.

Thirdly, managers of construction enterprises should strengthen the management consciousness of safety performance. Production safety is related to enterprises' health and sustainable development and is the common expectation of society and employees. It is essential to strengthen the maintenance and overhaul of safety facilities, improve the safety responsibility consciousness of employees and standardize the operation ability.

### Future Research Directions

Although this research has achieved established objectives, theoretical and practical results have been achieved. Based on these findings, we also provide directions and suggestions for future research:

First, we suggest that more scholars continue to explore the theme of the safety performance of construction enterprises in the future to provide more practical strategies to improve the safety performance of construction enterprises and contribute to the sustainable development of construction enterprises.

Secondly, we suggest that future researchers explore related research on the safety performance of construction enterprises in different contexts to provide a broader practical reference value for improving the safety performance of construction enterprises and contribute to the normative development of the construction industry.

Thirdly, we suggest that more scholars should pay attention to the research on employee behavior in construction enterprises in the future to provide a more practical reference for human resource management in construction enterprises, promote the personal development and social attention of employees in construction enterprises, and help improve the staff team building and human resource management ability of construction enterprises.

Finally, we suggest that in future studies, based on this research, scholars can discuss more factors that may affect the safety performance of construction enterprises, which is also a further improvement of this research and conducive to the academic theoretical supplement of this research theme.

### References

- Akinosho, T. D., Oyedele, L. O., Bilal, M., Ajayi, A. O., Delgado, M. D., Akinade, O. O., & Ahmed, A. A. (2020). Deep learning in the construction industry: A review of present status and future innovations. *Journal of Building Engineering*, 32. <https://doi.org/10.1016/j.jobbe.2020.101827>
- Amornkitpinyo, P., Amornkitpinyo, T., Satityapong, N., Wongrajit, S., & Thongnuypram, C. (2022). Social Innovation for quality of life. *Journal of Educational Management and Research Innovation*, 4(2), 279–286.
- Barni, D., Danioni, F., & Benevene, P. (2019). Teachers' self-efficacy: The role of personal values and motivations for teaching. *Frontiers in Psychology*, 10, 1645. <https://doi.org/10.3389/fpsyg.2019.01645>
- Beauchamp, M. R., Crawford, K. L., & Jackson, B. (2019). Social cognitive theory and physical activity: Mechanisms of behavior change, critique, and legacy. *Psychology of Sport and Exercise*, 42, 110–117. <https://doi.org/10.1016/j.psychsport.2018.11.009>
- Cable, D. M., & DeRue, D. S. (2002). The convergent and discriminant validity of subjective fit perceptions. *Journal of Applied Psychology*, 87(5), 875–884. <https://doi.org/10.1037/0021-9010.87.5.875>

- Chen, H. (2022). *Research on the Influence of Work Values on Employee Safety Performance under the Background of the New Coronary Pneumonia Epidemic*. Master's Thesis, Zhejiang University of Finance and Economics.
- Chen, H., & Li, W. (2019). Understanding commitment and apathy in security extra-role behavior from a person-organization fit perspective. *Behavior & Information Technology*, 38(5), 454-468. <https://doi.org/10.1080/0144929X.2018.1539520>
- Chen, W. T., Merrett, H. C., Huang, Y.-H., Bria, T. A., & Lin, Y.-H. (2021). Exploring the relationship between safety climate and worker safety behavior on building construction sites in Taiwan. *Sustainability*, 13(6), 3326. <https://doi.org/10.3390/su13063326>
- Darvishmotevali, M., & Ali, F. (2020). Job insecurity, subjective well-being and job performance: The moderating role of psychological capital. *International Journal of Hospitality Management*, 87, Article 102462. <https://doi.org/10.1016/j.ijhm.2020.102462>
- Doménech-Betoret, F., Abellán-Roselló, L., & Gómez-Artiga, A. (2017). Self-efficacy, satisfaction, and academic achievement: the mediator role of Students' expectancy-value beliefs. *Frontiers in Psychology*, 8, 1193. <https://doi.org/10.3389/fpsyg.2017.01193>
- Eastman, C., & Marzillier, J. S. (1984). Theoretical and methodological difficulties in Bandura's self-efficacy theory. *Cognitive Therapy and Research*, 8(3), 213–229. <https://doi.org/10.1007/BF01172994>
- Fu, G., Xie, X., Jia, Q., Li, Z., Chen, P., & Ge, Y. (2020). The development history of accident causation models in the past 100 years: 24Model, a more modern accident causation model. *Process Safety and Environmental Protection*, 134, 47-82. <https://doi.org/10.1016/j.psep.2019.11.027>
- Guo, Y., & Liu, Y. (2022). Sustainable poverty alleviation and green development in China's underdeveloped areas. *Journal of Geographical Sciences*, 32(1), 23-43. <https://doi.org/10.1007/s11442-021-1932-y>
- Holden, G., Barker, K., Kuppens, S., & Rosenberg, G. (2017). Self-efficacy regarding social work competencies. *Research on Social Work Practice*, 27(5), 594-606. <https://doi.org/10.1177/10497315155586>
- Hou, P. (2019). *Research on individual-enterprise value fit, work performance and work happiness*[Master's Thesis, Shaanxi University of Science and Technology].
- Ismail, N. H. (2021). Impact of environment congruency on organizational performance: The mediating effect of culture and strategy. *The Euraseans: Journal On Global Socio-Economic Dynamics*, 4(29), 86-97. [https://doi.org/10.35678/2539-5645.4\(29\).2021.86-97](https://doi.org/10.35678/2539-5645.4(29).2021.86-97)
- Jalalkamali, M., Ali, A. J., Hyun, S. S., & Nikbin, D. (2016). Relationships between work values, communication satisfaction, and employee job performance: The case of international joint ventures in Iran. *Management Decision*, 54(4), 796–814. <https://doi.org/10.1108/MD-01-2015-0003>
- Javed, B., Fatima, T., Khan, A. K., & Bashir, S. (2021). Impact of inclusive leadership on innovative work behavior: the role of creative self-efficacy. *The Journal of Creative Behavior*, 55(3), 769-782. <https://doi.org/10.1002/jocb.487>
- Jazayeri, E., & Dadi, G. B. (2017). Construction safety management systems and methods of safety performance measurement: A review. *Journal of Safety Engineering*, 6(2), 15-28. <https://doi.org/10.5923/j.safety.20170602.01>
- Jin, M. H., McDonald, B., & Park, J. (2018). Person–organization fit and turnover intention: Exploring the mediating role of employee followership and job satisfaction through

- conservation of resources theory. *Review of Public Personnel Administration*, 38(2), 167-192. <https://doi.org/10.1177/0734371X1665833>
- Kang, L., & Wu, C. (2020). Evaluating the safety performance of China's provincial construction industries from 2009 to 2017. *Journal of Civil Engineering and Management*, 26(5), 435-446. <https://doi.org/10.3846/jcem.2020.12646>
- Kang, L., Wu, C., Liao, X., & Wang, B. (2020). Safety performance and technology heterogeneity in China's provincial construction industry. *Safety Science*, 121, 83-92. <https://doi.org/10.1016/j.ssci.2019.09.005>
- Ke, X., & Yang, H. (2021). A review study of the impact of person-organization fit on lecturers' creativity. *IETI Transactions on Economics and Management*, 3(1), 6-24. [https://doi.org/10.6897/IETITEM.202111\\_3\(1\).0002](https://doi.org/10.6897/IETITEM.202111_3(1).0002)
- Li, F., & Qi, T. (2017). Can employee suggestions improve job performance? the role of suggestion adoption and self-efficacy. *China Human Resource Development*, 12(08), 71-82.
- Li, N., & Zhao, Y. (2020). Research on the relationship between miners' self-efficacy and safety performance: based on the chain mediating effect of autonomous safety motivation and work engagement. *Science and Technology for Development*, 16(06), 689-695.
- Liu, Y., Li, J., & Yang, Y. (2018). Strategic adjustment of land use policy under the economic transformation. *Land use policy*, 74, 5-14. <https://doi.org/10.1016/j.landusepol.2017.07.005>
- Luo, T. (2020). Safety climate: current status of the research and future prospects. *Journal of Safety Science and Resilience*, 1(2), 106-119.
- Lou, X. (2018). *The relationship between value fit and job performance: the mediating role of organizational support and the moderating role of psychological capital*[Master's Thesis, Zhejiang University].
- Lyu, S., Hon, C. K., Chan, A. P., Wong, F. K., & Javed, A. A. (2018). Relationships among safety climate, safety behavior, and safety outcomes for ethnic minority construction workers. *International Journal of Environmental Research and Public Health*, 15(3), 484. <https://doi.org/10.3390/ijerph15030484>
- Ma, Y., & Liu, Y. (2021). The impact of safety value fit on miners' safety behavior: A chain intermediary model. *Chinese Journal of Safety Science*, 31(02), 9-15.
- Maliha, M. N., Abu Aisheh, Y. I., Tayeh, B. A., & Almalki, A. (2021). Safety barriers identification, classification, and ways to improve safety performance in the architecture, engineering, and construction (AEC) industry: A review study. *Sustainability*, 13(6), 3316. <https://doi.org/10.3390/su13063316>
- Mao, H. (2013). *An empirical study on the effect of individual-organization fit on job performance: The mediating effect of self-efficacy*[Master's Thesis, Nanjing University of Posts and Telecommunications].
- Mao, Z. (2016). *Research on the relationship between personal-organization value fit and job performance in the IT industry*[Master's Thesis, Yunnan University of Finance and Economics].
- Mi, L., Sun, Y., Gan, X., Yang, H., Lv, T., Shang, K., Qiao, Y., & Jiang, Z. (2020). Promoting employee green behavior through the person-organization fit: The moderating effect of psychological distance. *Frontiers in Psychology*, 11, 568385. <https://doi.org/10.3389/fpsyg.2020.568385>
- Na, Y. & Li, J. (2019). Research on the relationship between work values, regulatory focus and safety performance: based on the empirical analysis of the new generation employees



- in coal mining enterprises. *China Safety Production Science and Technology*, 15(08), 162-167.
- Neal, A., & Griffin, M. A. (2002). Safety climate and safety behavior. *Australian Journal of Management*, 27(1\_suppl), 67-75. <https://doi.org/10.1177/031289620202701S08>
- Newaz, M. T., Davis, P., Jefferies, M., & Pillay, M. (2019). Using a psychological contract of safety to predict safety climate on construction sites. *Journal of Safety Research*, 68, 9-19. <https://doi.org/10.1016/j.jsr.2018.10.012>
- Newaz, M. T., Ershadi, M., Jefferies, M., Pillay, M., & Davis, P. (2023). A systematic review of contemporary safety management research: A multi-level approach to identifying trending domains in the construction industry. *Construction Management and Economics*, 41(2), 97-115. <https://doi.org/10.1080/01446193.2022.2124527>
- Nguyen, H., Johnson, A., Collins, C., & Parker, S. K. (2017). Confidence matters: self-efficacy moderates the credit that supervisors give to adaptive and proactive role behaviors. *British Journal of Management*, 28(2), 315-330. <https://doi.org/10.1111/1467-8551.12149>
- Pataki-Bittó, F. (2021). Work environment transformation in the post-COVID-19 based on work values of the future workforce. *Journal of Corporate Real Estate*, 23(3), 151-169. <https://doi.org/10.1108/JCRE-08-2020-0031>
- Pourmazaherian, M., & Musonda, I. (2022). Worker competence and safety performance the mediation role of safety orientation in construction industry. *Cogent Public Health*, 9(1), 2145702. <https://doi.org/10.1080/27707571.2022.2145702>
- Putri, A., Dahlia, D., Maria, R., & Sitorus, R. (2018). Relationship between the knowledge on self-efficacy about counseling and stoma site marking for patients undergoing stoma surgery in etns. *The Malaysian Journal of Nursing*, 9(3), 54-60.
- Rahimi Pordanjani, T., & Mohammadzade Ebrahimi, A. (2015). The effect of employees' management commitment to safety and consciousness on unsafe performance: The mediating role of safety self-efficacy. *Journal of Health and Safety at Work*, 4(4), 69-80.
- Schunk, D. H., & DiBenedetto, M. K. (2020). Motivation and social cognitive theory. *Contemporary Educational Psychology*, 60, Article 101832. <https://doi.org/10.1016/j.cedpsych.2019.101832>
- Shi, X., Lin, F., & He, J. (2019). The impact of motivating job gamification design on employee job performance: with self-efficacy as an intermediary variable. *Technology and Management*, 21(4), 105-110.
- Silva, S. L. C., & Amaral, F. G. (2019). Critical factors of success and barriers to the implementation of occupational health and safety management systems: A systematic review of the literature. *Safety Science*, 117, 123-132. <https://doi.org/10.1016/j.ssci.2019.03.026>
- Su, Y., Yang, S., Liu, K., Hua, K., & Yao, Q. (2019). Developing a case-based reasoning model for safety accident pre-control and decision-making in the construction industry. *International Journal of Environmental Research and Public Health*, 16(9), 1511. <https://doi.org/10.3390/ijerph16091511>
- Sukamani, D., Wang, J., & Kusi, M. (2021). Impact of safety worker behavior and safety climate as mediator and safety training as moderator on safety performance in construction firms in Nepal. *KSCE Journal of Civil Engineering*, 25(5), 1555-1567. <https://doi.org/10.1007/s12205-021-1468-9>
- Sukamani, D., Wang, J., Kusi, M., & Shah, A. (2020). Impact of safety worker behaviour on safety performance in construction firm of Nepal; a moderated mediation model. *Engineering Letters*, 28(4), 1271-1286.

- Sulistyo, A. R., & Suhartini, S. (2019). The role of work engagement in moderating the impact of job characteristics perceived organizational support, and self-efficacy on job satisfaction. *Integrated Journal of Business and Economics*, 3(1), 15-31. <https://doi.org/10.33019/ijbe.v3i1.112>
- Sun, W., Yang, J., Xu, C., Wan, Y. (2018). A study on the relationship between self-efficacy and safety performance of civil aviation pilots. *Journal of Safety and Environment*, 18(04), 1359-1363.
- Tong, L., Chen, Y., Jin, L., & Zheng, X. (2022). Regional sustainable performance of construction industry in China from the perspective of input and output: considering occupational safety. *Buildings*, 12(5), 618. <https://doi.org/10.3390/buildings12050618>
- Tremblay, A., & Badri, A. (2018). Assessment of occupational health and safety performance evaluation tools: State of the art and challenges for small and medium-sized enterprises. *Safety Science*, 101, 260-267. <https://doi.org/10.1016/j.ssci.2017.09.016>
- Trinh, M. T., & Feng, Y. (2020). Impact of project complexity on construction safety performance: Moderating role of resilient safety culture. *Journal of Construction Engineering and Management*, 146(2), 04019103. [https://doi.org/10.1061/\(ASCE\)CO.1943-7862.0001758](https://doi.org/10.1061/(ASCE)CO.1943-7862.0001758)
- Wang, C., & Li, H. (2022). Do not worry about less but worry about inequality: The importance of interactive fairness in the performance appraisal of University faculty. *International Journal of Multidisciplinary in Management and Tourism*, 6(2), 169–186. <https://doi.org/10.14456/ijmmt.2022.14>
- Wilde, N., & Hsu, A. (2019). The influence of general self-efficacy on the interpretation of vicarious experience information within online learning. *International Journal of Educational Technology in Higher Education*, 16(1), 1-20. <https://doi.org/10.1186/s41239-019-0158-x>
- Wongsuwan, N., & Na-Nan, K. (2022). Mediating effects of self-efficacy, resilience and job satisfaction on the relationship between person–organisation fit and employee work adjustment. *Sustainability*, 14(18), 11787. <https://doi.org/10.3390/su141811787>
- Wu, T. J., Gao, J. Y., Wang, L. Y., & Yuan, K. S. (2020). Exploring links between polychronic and job performance from the person-environment fit perspective-The mediating role of well-being. *International Journal of Environmental Research and Public Health*, 17(10), 3711. <https://doi.org/10.3390/ijerph17103711>
- Yang, H. (2022). *Identification and evaluation of factors influencing safety performance of construction enterprises*[Master's Thesis, Wuhan University of Science and Technology].
- Yang, F., & Deng, H. (2020). The impact of empowering leader behavior on employees' voice behavior: the role of person-environment fit and the golden mean. *Resource*, 11(1), 71-81.
- Yasmeen, B. B. (2021). Reciprocal relationship among job crafting, work engagement, leader-member exchange, and person-environment fit: A study of tourist guide in Pakistan. *Journal of Workplace Behavior*, 2(1), 30-45.
- Ye, G., Xiang, Q., Yang, L., Yang, J., Xia, N., Liu, Y., & He, T. (2022). Safety stressors and construction workers' safety performance: The mediating role of ego depletion and self-efficacy. *Frontiers in Psychology*, 12, 818955. <https://doi.org/10.3389/fpsyg.2021.818955>
- Zhang, F. (2021). *Research on the impact path of safety culture on safety performance in small and medium-sized construction enterprises*[Master's Thesis, Changsha University of Science and Technology].